

a)
A cuboidal container, as shown in the first diagram, is filled with water to a depth of 18cm, and sealed.

The container is then rotated as shown in the second diagram.

What is the depth of the water in the container in the second diagram?

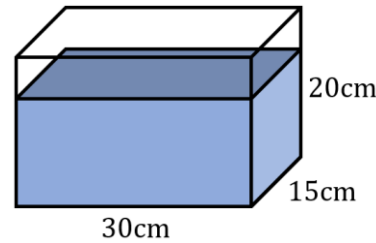
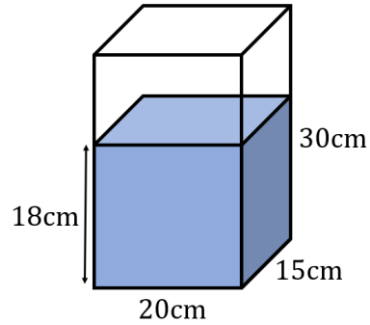

a)
A cuboidal container, as shown in the first diagram, is filled with water to a depth of 18cm, and sealed.

The container is then rotated as shown in the second diagram.

What is the depth of the water in the container in the second diagram?

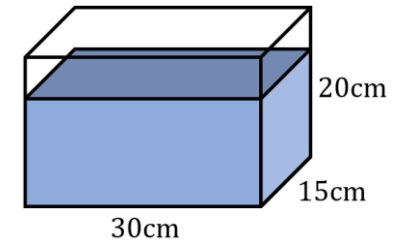
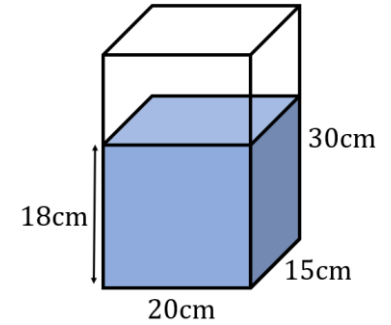

b)
A cuboidal container, as shown in the diagram, is completely filled with water, and sealed.

A hole is drilled on the front face and water leaks out so that the volume decreases by 4000cm^3 .

Describe the position of the drilled hole.

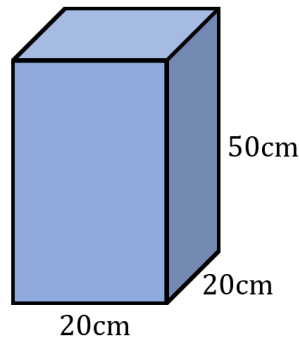

b)
A cuboidal container, as shown in the diagram, is completely filled with water, and sealed.

A hole is drilled on the front face and water leaks out so that the volume decreases by 4000cm^3 .

Describe the position of the drilled hole.

